

Product data sheet

Characteristics

8910DPA43V04

Contactor, Definite Purpose, 40A, 3 pole, 25 HP at 575 VAC, 3 phase, 277 VAC 60 Hz coil, open



Product availability: Stock - Normally stocked in distribution facility

Price*: 113.25 USD



Main

Product or component type	Definite Purpose Contactor
Line Rated Current	40 A
Poles description	3P
Pole contact composition	3 NO
Range of product	DPA

Complementary

Maximum Horse Power Rating	3 Hp 115 V AC, 1 phase 7.5 Hp 230 V AC, 1 phase 10 Hp 230 V AC, 3 phase 20 Hp 460 V AC, 3 phase 25 Hp 575 V AC, 3 phase
Locked rotor rated current	240 A 277 V AC 200 A 460 V AC 160 A 575 V AC
[Ue] rated operational voltage	600 V AC
[Uc] control circuit voltage	277 V AC 60 Hz
Phase	3 phase
Electrical connection	Box lugs Quick connect terminals

Environment

Product certifications	UL Recognized CSA
------------------------	----------------------

The information provided in this documentation contains general descriptions and/or technical characteristics of the performance of the products contained herein. This documentation is not intended as a substitute for and is not to be used for determining suitability or reliability of these products for specific user applications. It is the duty of any such user or integrator to perform the appropriate and complete risk analysis, evaluation and testing of the products with respect to the relevant specific application or use thereof. Neither Schneider Electric Industries SAS nor any of its affiliates or subsidiaries shall be responsible or liable for misuse of the information contained herein. *Prices are indicative

Ordering and shipping details

Category	21344 - 8910 DPA 4_(40 AMP)
Discount Schedule	CP1B
GTIN	00785901024477
Nbr. of units in pkg.	1
Package weight(Lbs)	18.88 Oz (535.239 g)
Returnability	Yes
Country of origin	CN

Packing Units

Unit Type of Package 1	PCE
Package 1 Height	3.20 In (8.128 cm)
Package 1 width	2.60 In (6.604 cm)
Package 1 Length	4.00 In (10.16 cm)
Unit Type of Package 2	CAR
Number of Units in Package 2	8
Package 2 Weight	9.82 Lb(US) (4.454 kg)
Package 2 Height	6.90 In (17.526 cm)
Package 2 width	5.50 In (13.97 cm)
Package 2 Length	8.50 In (21.59 cm)

Offer Sustainability

REACH Regulation	REACH Declaration
EU RoHS Directive	Compliant EU RoHS Declaration
Mercury free	Yes
RoHS exemption information	Yes
China RoHS Regulation	China RoHS Declaration

Contractual warranty

Warranty	18 months
----------	-----------

Approximate Dimensions

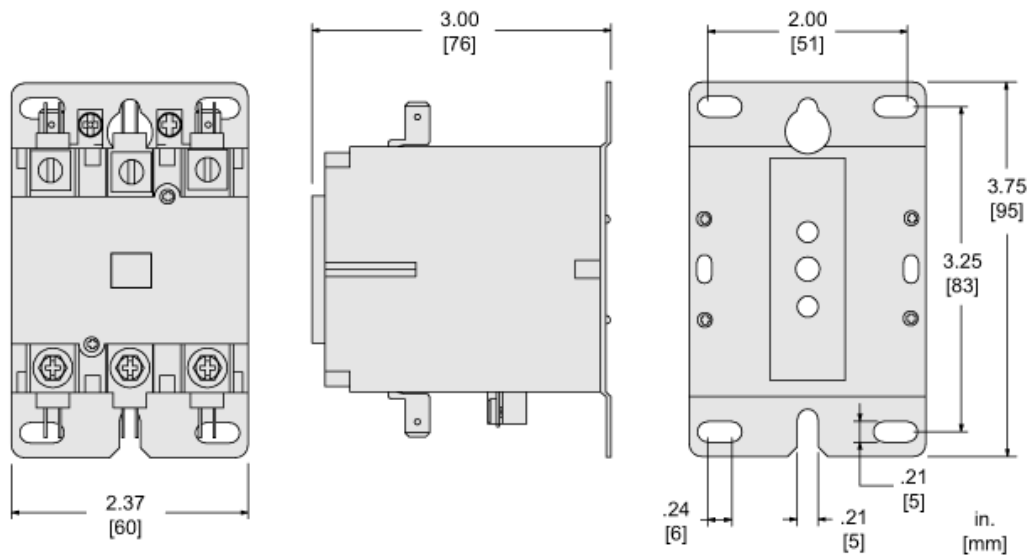

Product Life Status : Commercialised